

## **1. GENERAL INFORMATION**

### **1.1 APPLICATION**

This TWS-SIREN SERIES are the market leading high power voice and siren system. Its construction provides superior audio quality combined with the highest output to power consumption ratio. The sirens are suitable for outdoor public warning and general alarm in any climatic conditions. As such have our sirens been installed in various places ranging from the snow covered inlands of Greenland to the hot and arid desert climate in the Kingdom of Saudi Arabia. The sirens superior durability has proved itself over and over again with many installations more than 15 years old - and still running. We hope that our siren will live up to your expectations and prove itself as the obvious choice for an outdoor siren system.

Best Regards

Christian Secher Schmidt  
Technical Manager



**ATTENTION:** PRIOR TO INSTALLING THE TWS SIREN UNIT THESE INSTRUCTIONS MUST BE READ CAREFULLY!



**ATTENTION:** INSTALLATION OF THE TWS SIREN UNIT MAY INCLUDE HEAVY MACHINERY AND HEAVY LIFTING. INSTALLATION IS ONLY TO BE CARRIED OUT BY QUALIFIED AND EXPERIENCED PERSONEL!



**ATTENTION:** THE TWS SIREN CAN PRODUCE AN AUDIO OUTPUT THAT MAY BE HARMFULL TO YOUR HEARING. PROPER PRECAUTIONS SHOULD BE TAKEN AND INSTALLATION IS ONLY TO BE CARRIED OUT BY QUALIFIED AND EXPERIENCED PERSONEL!



**WARNING:** THIS SYSTEM INLCUDES HIGH VOLTAGE ELECTRICAL WIRING. TO PREVENT ELECTRIC SHOCK INSTALLATION IS ONLY TO BE CARRIED OUT BY QUALIFIED AND EXPERIENCED PERSONEL!

## 2. INDEX

1.	GENERAL INFORMATION .....	1
1.1	APPLICATION.....	1
2.	INDEX .....	3
3.	INSTALLATION.....	4
3.1	SITE SELECTION.....	5
3.2	UTILITY MAST SELECTION.....	6
3.3	ERECTION OF MAST.....	7
4.	ELECTRICAL CONNECTION .....	20
4.1	SPEAKER CABLE CONNNECTION - AMPLIFIERS .....	23
5.	SERVICE AND TROUBLESHOOTING .....	25
5.1	SIREN CLUSTER.....	25
5.2	STATION COMPONENTS DEFINED.....	28
6.	SYSTEM OPERATIONS.....	30
6.1	REMOTE OPERATIONS.....	30
6.2	LOCAL OPERATIONS .....	30
7.	UNDERSTANDING STATION ADDRESSING .....	32
7.1	TROUBLESHOOTING .....	39
8.	MAINTENANCE .....	43
8.1	FREQUENCY OF TESTING AND ACTIVATION.....	43
8.2	QUATERLY MAINTENANCE .....	44
8.3	VISUAL SIREN STATION PHYSICAL INSPECTION .....	44

### 3. INSTALLATION

---

The installation manual for the TWS SIREN follows a logical progression. This progress is not arbitrary! It was developed using information gathered from both manufacturer and field technicians. Deviations from any of these procedures are not recommended unless they are in contradiction with local codes. **IN ALL INSTANCES, LOCAL CODES TAKES PRECEDENT OVER PROCEDURES OUTLINED HEREIN!**

It is the responsibility of the installation technicians to read this entire manual. The installation procedure should not begin until all personnel are familiar with the entire process. The overall installation procedure includes the following:

Installation Procedure	
1	Site Selection
2	Utility Mast Selection
3	Erection of Mast: <ol style="list-style-type: none"> <li>1) Foundation</li> <li>2) Siren Speaker Cluster</li> <li>3) Installation of Cabinet / Sun Shield (Optional)</li> <li>4) Installation of antenna (Optional)</li> <li>5) Installation of Solar Panels (Optional)</li> <li>6) Grounding</li> <li>7) Installation of AC</li> <li>8) Installation of Solar Panels (Optional)</li> <li>9) Installation of batteries</li> </ol>
4	Confirmation of proper system operation.

### 3.1 SITE SELECTION

---

The site selection for the TWS SERIES SIREN requires careful consideration in order to achieve the optimum coverage of the siren station. For a guideline to system planning, sound propagation and site selection we direct the user to the Federal Emergency Management Agency's "Outdoor Warning Systems Guide, CPG 1-17" and EN 60849:1998 European Norm: "Sound systems for emergency purposes".

The location of the siren site should be reviewed for its compatibility with its surroundings such as private homes, schools and hospitals.

The location of the siren site should be reviewed for blocking obstacles such as buildings, high noise areas etc., that might reduce the expected coverage of the siren.

The user is cautioned to consider the use of hearing protection devices for service personnel working in close proximity to the speaker cluster.

Access to the siren site is important from the standpoint of service, maintenance, inspection and access to a utility service connect.

Site locations for radio controlled units should be reviewed for radio reception.

### 3.2 UTILITY MAST SELECTION

---

The following parameters are important when selecting a utility mast for the TWS siren:

1. Dimensioning weight of siren equipment (please refer to TWS Siren Series data sheets).
2. Dimensioning wind load of siren equipment (please refer to TWS Siren Series data sheets) and other components such as solar panels.
3. Audible siren sound output related to surrounding buildings etc. It is important to ensure that siren sound output is not blocked by major obstacles such as buildings etc.
4. Audible siren sound output related to distance to the listener. Siren output should not surpass 120 dB at the location of the listener (please refer to BS EN 60849:1998).
5. Accessibility during service. Should mast be equipped with service platform or other features in order to facilitate service and maintenance of the siren?

### 3.3 ERECTION OF MAST



**ATTENTION:** THIS INSTALLATION MANUAL ADDRESS PROCEDURES APPLICABLE TO HSS ENGINEERING STANDARD 12 METER STEEL UTILITY MASTS (TWS-FSM-12)). PROCEDURES FOR OTHER TYPES OF POLES ARE NOT ADRESSED IN THIS DOCUMENT. THE INFORMATION PRESENTED, HOWEVER, PROVIDES THE NECESSARY DATA AND GUIDELINES FOR A SUCCESSFUL INSTALLATION REGARDLESS OF POLE TYPE / MATERIAL. IN ALL INSTANCES, LOCAL CODES TAKES PRECEDENSE OVER PROCEDURES OUTLINED HEREIN.

#### 3.3.1 FOUNDATION

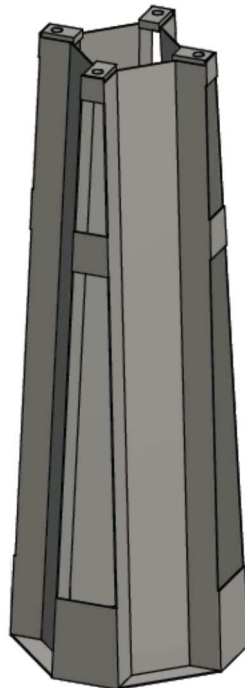

**Figure 1 - Prefab steel foundation for TWS-FSM-12**

1. Make an excavation of 100cm x 100cm and 150cm deep.
2. Level bottom of excavation before placing the prefab steel foundation.
3. Place prefab steel foundation while ensuring that all bolts for mast are above final terrain level and that foundation is in level.

4. Backfill 2/3 of the excavation using stone size 32-64mm.
5. If sub terrain cables are used these can now be pulled through side of foundation and then through top of foundation
6. Last 1/3 is filled with sand.
7. Inside of foundation is filled with sand.
8. Compact backfill material

Alternatively concrete can be used as backfill material.

### **3.3.2 MAST / SIREN CLUSTER**

1. Sling or cradle the utility pole in a safe manner so that the pole top is 50cm – 100cm off the ground. This will allow the speaker assembly to clear the ground when installed.
2. Locate the 4 mounting studs on the bottom of the speaker assembly (see Fig. 1). Please be aware that studs are placed in an uneven pattern (see Fig. 2).
3. Thread a 3/4" hex nut onto each of the mounting studs until there is approx. 20mm of space between the top of the nuts and the bottom of the siren assembly. This space will allow the speaker assembly to be leveled once the pole has been set.
4. Install a  $\varnothing 22$ mm flat washer onto each of the mounting studs.
5. Insert the four mounting studs through the mounting holes on the top of the pole top bracket. The bottom of the siren assembly should lie flat against the pole top bracket.
6. Install a  $\varnothing 22$ mm flat washer onto each of the mounting studs.
7. Install a  $\varnothing 22$ mm split lock-washer onto each of the mounting studs.
8. Thread a 3/4" hex nut onto each of the mounting studs. Tighten this nut firmly to secure the siren assembly to the pole top bracket.
9. At this point the pole should now be set. However, the installer may use their own discretion as to whether to mount the electronic cabinet, solar panels (optional) and antenna (optional) onto the utility pole before the pole is set.
10. When the pole has been set, use the adjustment nuts to adjust the mast until it is level.
11. When the pole has been leveled, use the adjustment nuts on speaker cluster to adjust this into level.



12. Install grounding (for example grounding rod) as specified by local codes and connect both copper wires (from mast and electronic cabinet) hereto.

Parts included with siren cluster	
PART	QUANTITY
TWS-SIREN SPEAKER CLUSTER	1
WASHER $\varnothing 22\text{mm}$ ,	8
LOCK WASHER $\varnothing 20\text{mm}$	4
HEX NUT $\frac{3}{4}\text{"-10}$	8
5 x 2 PAIR (RED/BLACK) $2.5\text{mm}^2$ SPEAKER CABLE, 15 MTR.	1

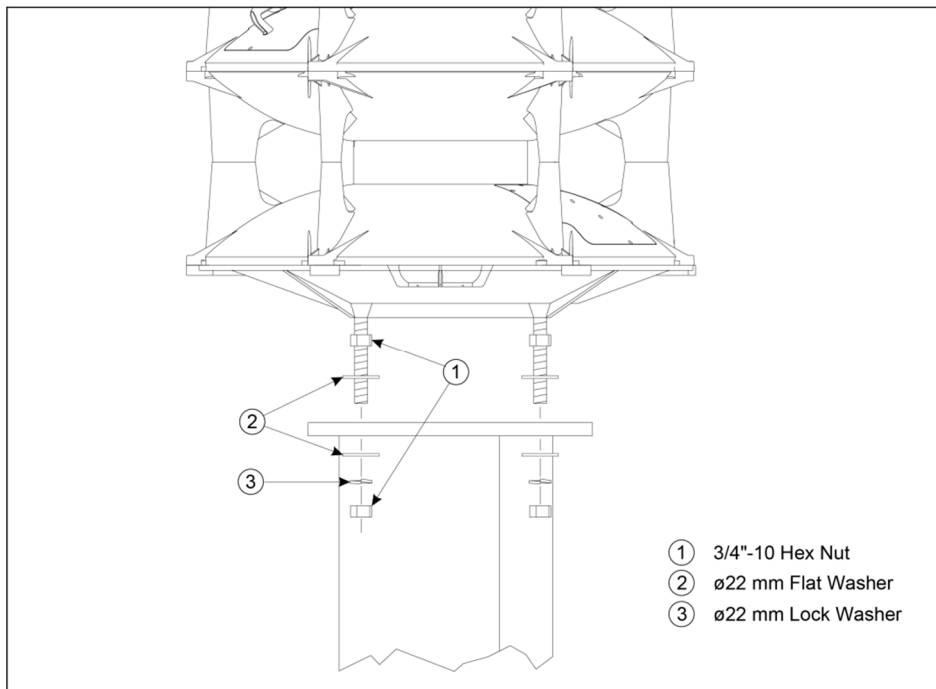
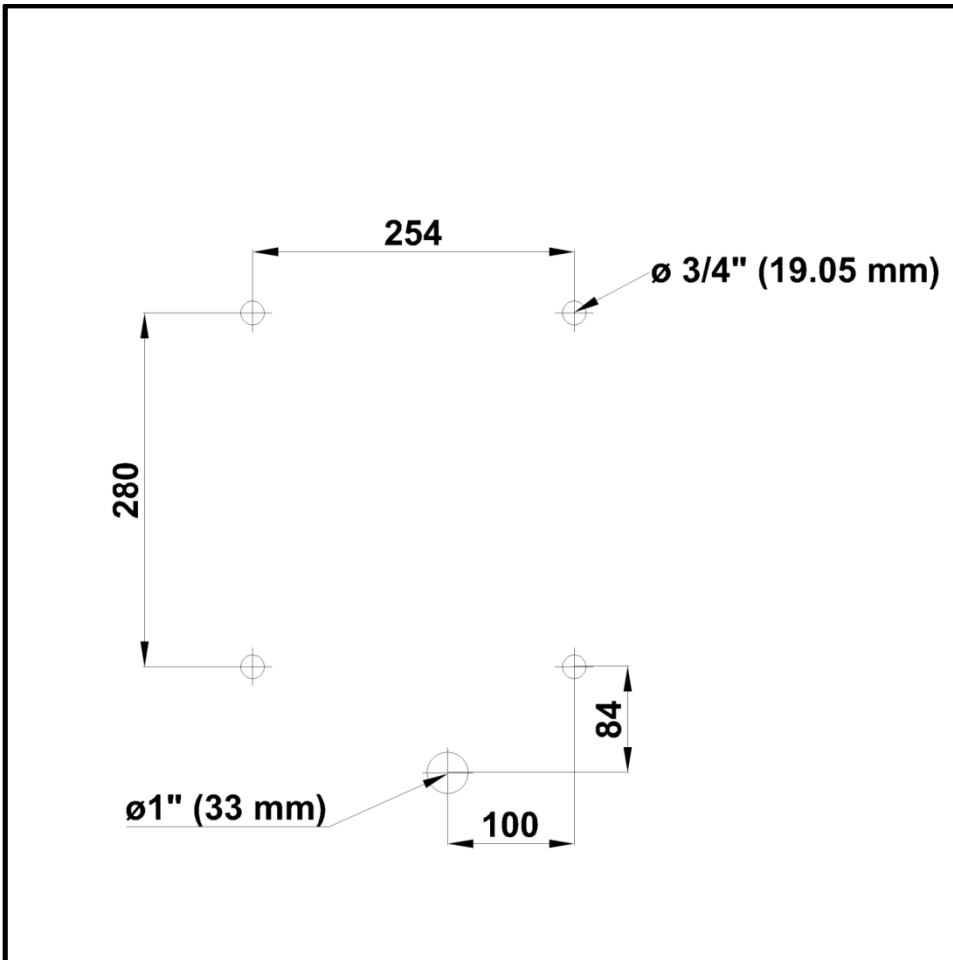

Figure 2 - MOUNTING OF SPEAKER CLUSTER



**Figure 3 - DIMENSIONS MOUNTING BOLTS SIREN CLUSTER BASE PLATE**

### 3.3.3 CABINET / SUN SHIELD

1. It is necessary for the installer to remember that two factors should determine the optimum mounting location; the desired distance of the mounted cabinet to the ground (typically 100 cm to 200 cm as measured from the bottom of the cabinet) and available speaker wire length (speaker assemblies are provided with a minimum of 15 meters of speaker cable as measured from the bottom of the speaker assembly).
2. After the mounting location has been determined, install the mounting brackets supplied with the mast with a c-c distance of 810 mm.
3. Mount cabinet sunshield (optional) loosely on the M8 bolts supplied with the cabinet mounting bracket.
4. Mount the cabinet onto the M8 bolts supplied with the mounting bracket using the threaded M8 entries on the back of the cabinet. Tighten firmly.
5. Use the M8 threaded entry on the side of the cabinet to install grounding.
6. If local codes require so a rigid steel conduit can be installed and necessary couplings from the speaker clusters 1" conduit adapter to the  $\varnothing$  25mm speaker cable entry on the siren cabinet. The first section of conduit may be installed onto the speaker's base casting prior to mounting the speaker to the pole top. At the option of the user, conduit unions may be used between the first section of conduit and the speaker base casting and at the speaker cable conduit entrance to the siren cabinet.
7. Batteries for the system should not be installed until the siren station is set in place!!!
8. Batteries should not be connected to the system until AC power (or solar power if equipped) is available to the system to operate the system's battery charger.

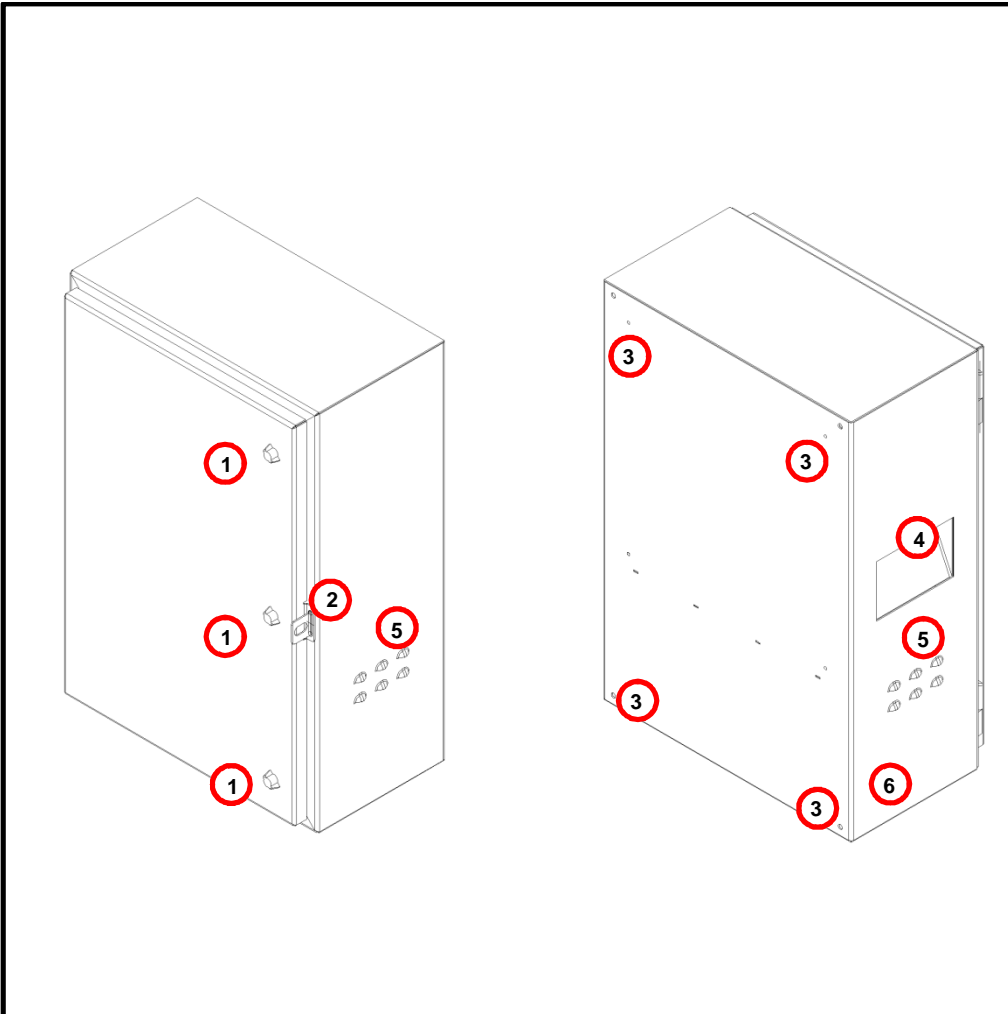

ITEM	DESCRIPTION
1	TURN LOCKS
2	FLANGE FOR PAD LOCKS
3	MOUNTING THREADS (M8)
4	CABLE ENTRIES
5	PASSIVE VENTILATION AIR INTAKE/OUTLETS
6	MOUNTING THREAD FOR GROUNDING (M8)

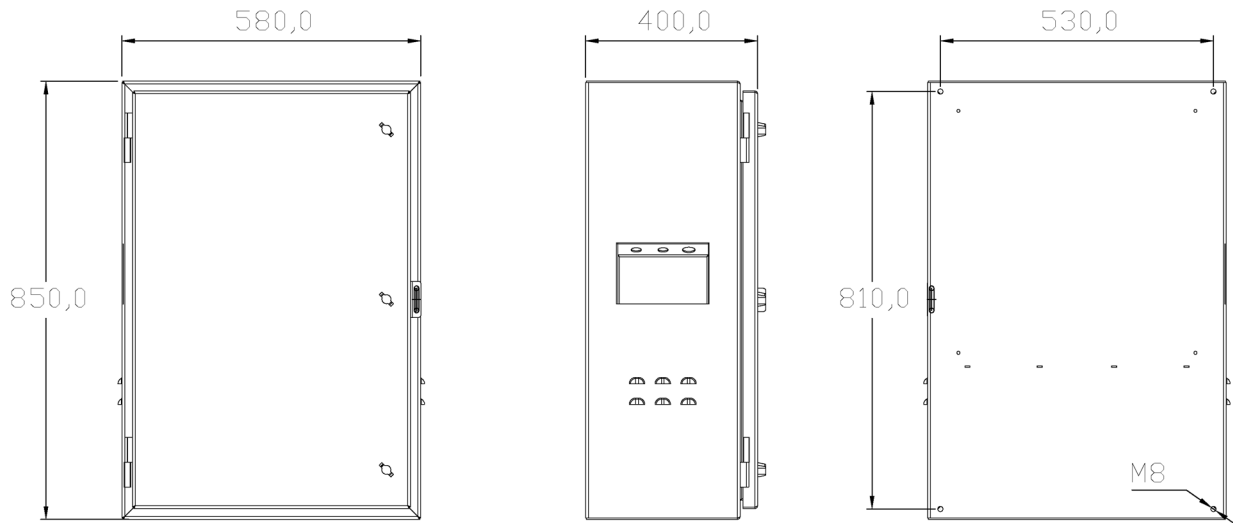

**Parts included with siren cabinet**

PART	QUANTITY
TWS-SIREN CABINET	1
CABLE GLAND Ø25mm FOR SPEAKER CABLE ENTRY	1
CABLE GLAND Ø20mm FOR OTHER CABLE ENTRIES (AC, COMMUNICATION CABLE ETC.)	3
BATTERY JUMPER CABLE	1
TUBE OF NYOGEL® FOR CORROSION PROTECTION OF BATTERY TERMINALS	1



**ATTENTION:** TO ENSURE PROPER AIRFLOW AT BATTERY COMPARTMENT MAKE SURE THAT AIR INTAKES AND OUTLET ARE NOT BLOCKED!



**ATTENTION:** DUE TO THE WEIGHT OF THE AMPLIFIER PANEL, THE ELECTRONIC CABINET MUST BE TRANSPORTED IN AN UPRIGHT FASHION TO PREVENT DISTORTION OF THE AMPLIFIER PANEL.



**ATTENTION:** BATTERIES FOR THE SYSTEM SHOULD NOT BE INSTALLED UNTIL THE SIREN STATION IS SET IN PLACE, OTHERWISE SOME LEAKAGE OF THE BATTERY FLUID MAY OCCUR. BATTERIES SHOULD NOT BE CONNECTED TO THE SYSTEM UNTIL AC POWER (OR SOLAR POWER IF EQUIPPED) IS AVAILABLE TO THE SYSTEM TO OPERATE THE SYSTEM'S BATTERY CHARGER.

### 3.3.4 INSTALLATION OF ANNTENNA (OPTIONAL)

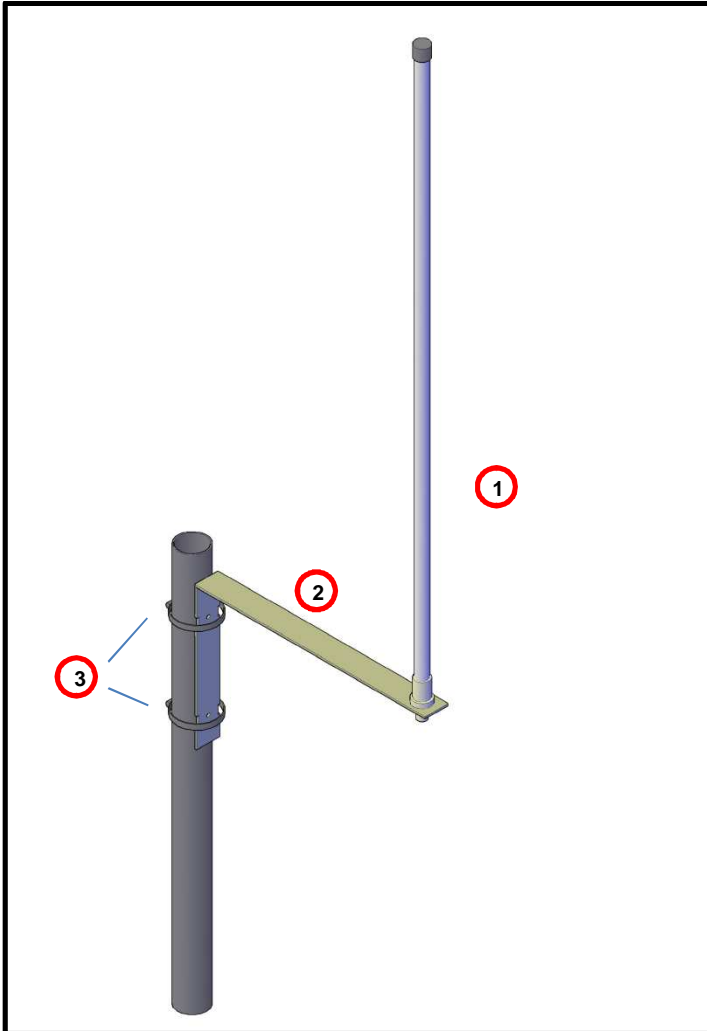

ITEM	DESCRIPTION
1	ANTENNA (NOTE: FREQUENCY TO SPECIFIED AT ORDER)
2	ANTENNA BRACKET
3	STEEL TYBE CLAMPS

Parts included with antenna	
PART	QUANTITY
ANTENNA	1 (NOTE: FREQUENCY TO BE SPECIFIED AT ORDER)
ANTENNA BRACKET	1
STEEL TUBE CLAMP 40-60 mm	2
15 mtr. RG213 w/ CONNECTORS	1

The proper antenna bracket mounting location is determined by several considerations.

1. The antenna bracket should be positioned as high on the utility pole as is possible. However, under no circumstances should the top of the antenna be any closer than 1 meter from the base of the siren cluster (see Fig 4).
2. Ensure proper grounding of antenna.
3. The antenna cable provided by the factory is a 15 meters RG213 coax cable.
4. The antenna **MUST** be mounted on the side of the utility pole that faces the transmitter (see Figure 3).
5. Refer to the installation sheet included with your antenna kit for further information regarding cable connections and antenna trimming.



**ATTENTION:** INSTALLATION MUST BE IN COMPLIANCE WITH ALL FCC REGULATIONS OR LOCAL EQUIVALENT AUTHORITY.



**ATTENTION:** FREQUENCY MUST BE SPECIFIED AT ORDER.

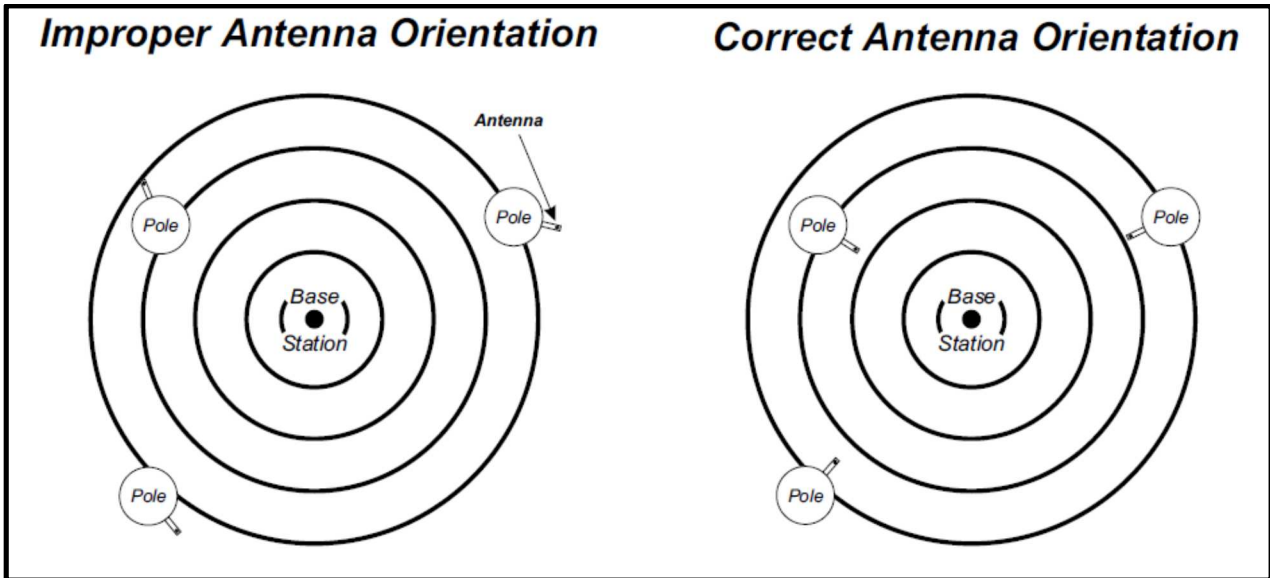

**Figure 4 - ANTENNA MOUNTING ORIENTATION**

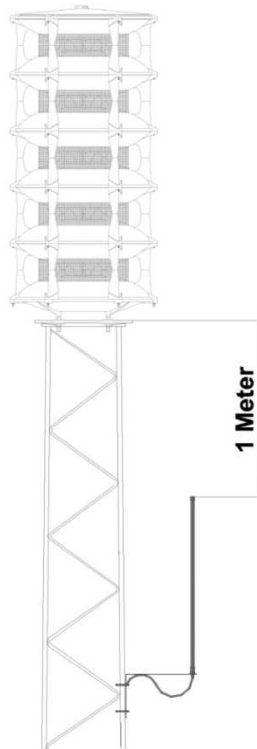

**Figure 5 - ANTENNA SHOULD BE MOUNTED AT LEAST 1 METER UNDER THE BASE OF THE SIREN CLUSTER**



### 3.3.5 INSTALLATION OF SOLAR PANELS (OPTIONAL)

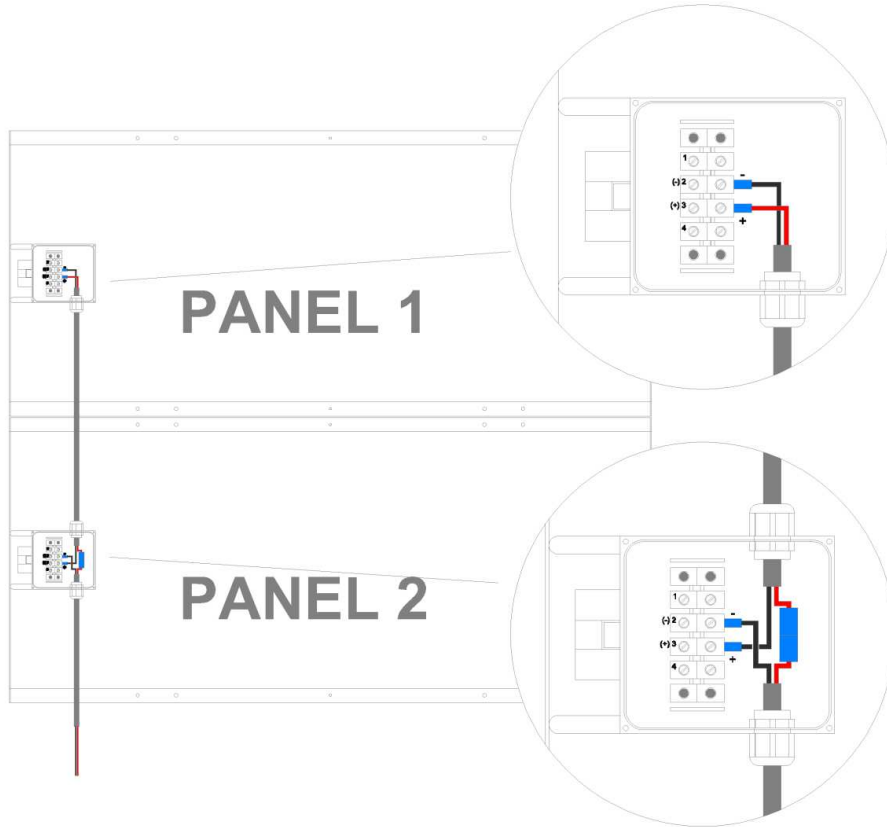

<b>Determining Solar Panel Mounting Angle</b>	
1	Determine the <i>LATITUDE</i> of your location.
2	Find your <i>Latitude</i> on the table below and not the corresponding <i>Tilt Angle</i> .
3	<p>Locate your <i>TILT ANGLE</i> in the list below. For every <i>TILT ANGLE</i>, there is a corresponding "Dimension A". "Dimension A" represents the distance from the bottom of the upper mounting bracket to the bottom of the lower mounting bracket.</p> <div style="display: flex; justify-content: space-between;"> <div style="width: 45%;"> <p>example 1:            Location <b>Latitude</b> is 30°            80° - 30° = 50° Tilt Angle            50° Tilt Angle = 33.60" Dimension A</p> </div> <div style="width: 45%;"> <p>example 2:            Location <b>Latitude</b> is 7°            7° = 75° Tilt Angle            75° Tilt Angle = 15.54" Dimension A</p> </div> </div>

Latitude	Tilt Angle
0° to 9°	75° = Tilt Angle
10° to 20°	85° minus LATITUDE = Tilt Angle
21° to 45°	80° minus LATITUDE = Tilt Angle
46° to 65°	75° minus LATITUDE = Tilt Angle
66° to 75°	10° minus LATITUDE = Tilt Angle

Tilt Angle	Dimension A (inches)	Tilt Angle	Dimension A (inches)	Tilt Angle	Dimension A (inches)
10	50.49	32	43.71	54	30.93
11	50.34	33	43.24	55	30.24
12	50.16	34	42.77	56	29.54
13	49.97	35	42.28	57	28.84
14	49.77	36	41.78	58	28.13
15	49.55	37	41.26	59	27.41
16	49.32	38	40.74	60	26.69
17	49.08	39	40.20	61	25.96
18	48.82	40	39.65	62	25.23
19	48.54	41	39.10	63	24.50
20	48.25	42	38.53	64	23.76
21	47.95	43	37.95	65	23.01
22	47.63	44	37.36	66	22.27
23	47.30	45	36.75	67	21.52
24	46.95	46	36.14	68	20.77
25	46.59	47	35.52	69	20.02
26	46.22	48	34.89	70	19.27
27	45.83	49	34.25	71	18.52
28	45.43	50	33.60	72	17.77
29	45.02	51	32.95	73	17.02
30	44.60	52	32.28	74	16.28
31	44.16	53	31.61	75	15.54

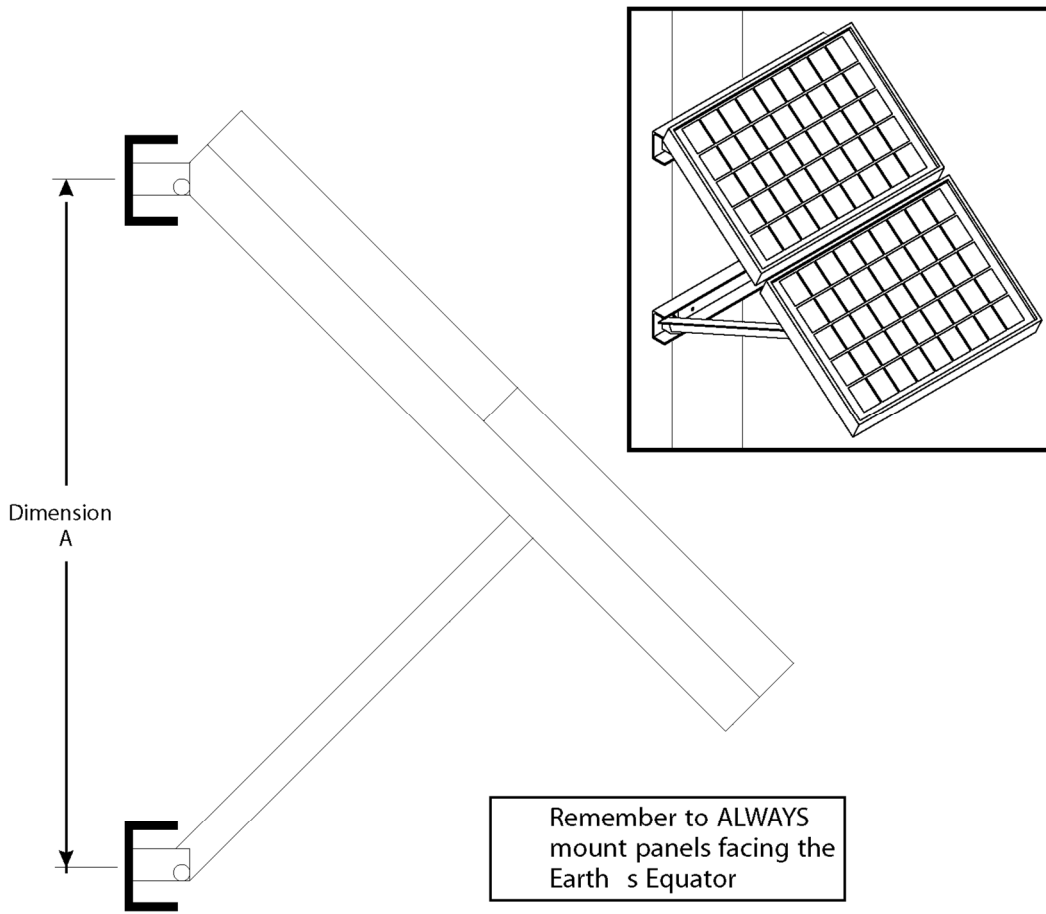

Lower Latitudes

Higher Latitudes

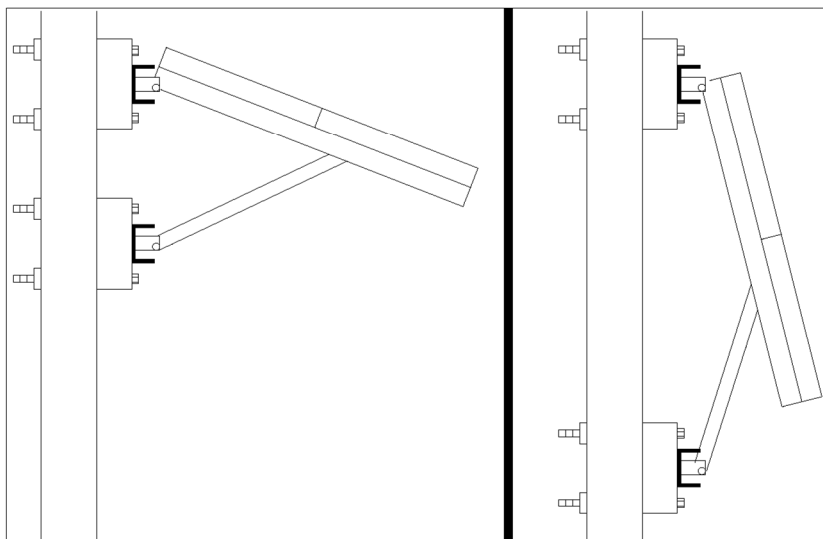

## 4. ELECTRICAL CONNECTION

---

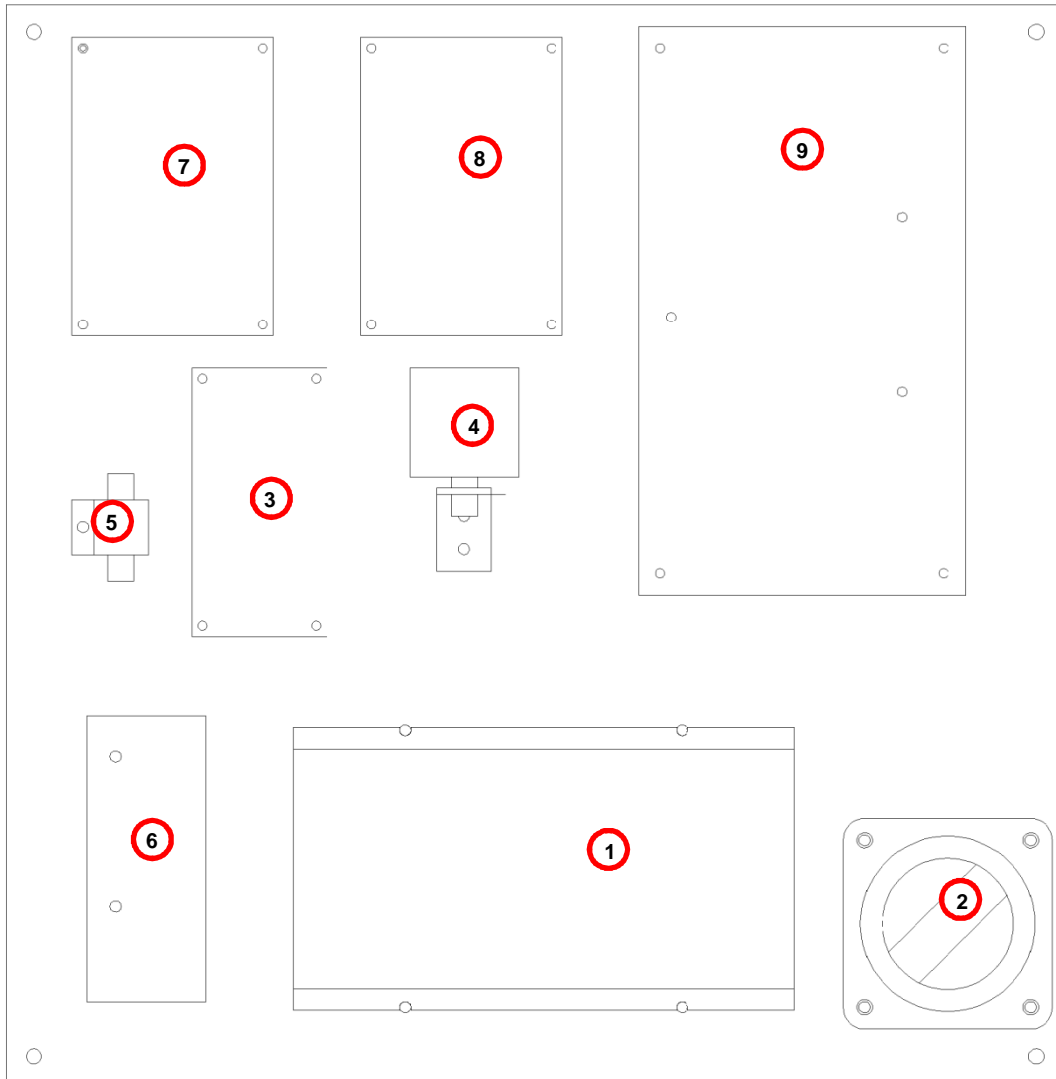

**Figure 6 - POSITION COMPONENTS BACK PLATE**

ITEM	DESCRIPTION
1	AC CHARGER
2	ON/OFF SWITCH
3	AC INTERFACE BOARD
4	AC LIGHTNING ARRESTOR
5	POLYPHASER (ONLY W/RADIO OPTION)
6	SOLAR REGULATOR (ONLY W/SOLAR OPTION)
7	FREE SLOT FOR OPTIONAL PRINT BOARD
8	FREE SLOT FOR OPTIONAL PRINT BOARD
9	FREE SLOT FOR OPTIONAL AUX PRINT BOARD



**ATTENTION:** PRIOR TO CONNECTING CABLES PLEASE ENSURE THAT THE SYSTEM IS SWITCHED OFF COMPLETELY!



**WARNING:** TO PREVENT ELECTRIC SHOCK DO NOT REMOVE TOP OR BOTTOM COVERS. NO USER SERVICEABLE PARTS INSIDE. REFER SERVICING TO CERTIFIED GIANT VOICE® SERVICE PERSONEL.



**WARNING:** DURING OPERATION THERE IS HAZARD OF HIGH VOLTAGE (100V) FROM SPEAKER CABLE CONNECTION. TO PREVENT ELECTRIC SHOCK INSTALLATION IS ONLY TO BE CARRIED OUT BY QUALIFIED PERSONEL.

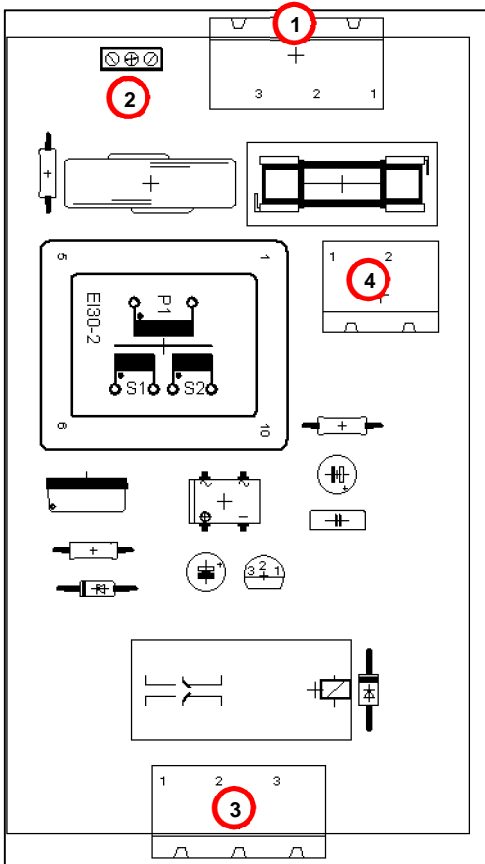

**Figure 7 - AC INLET**

ITEM	DESCRIPTION
1	AC INLET
2	C2030 CONTROL SIGNAL
3	OUTLET TO BATTERY CHARGER
4	OUTPUT FOR LIGHTNING ARRESTOR

#### 4.1 SPEAKER CABLE CONNECTION - AMPLIFIERS

The standard TWS speaker consists of 5 pairs of cable. Each set consist of a red and a black wire.cable This cable has 5 BLACK wires numbered 1 to 5 and 5 RED wires numbered 1 to 5. In systems with unused wires, dress the unused wires so they are out of the way. Do not cut these wires, as they can be used to support future upgrades of the siren ie going from 4 to 5 speaker cells.

The following procedure provides the information necessary for successfully connecting the siren harness wires to their designated amplifiers. Depending upon the distance between the siren base and the electronic cabinet, there will be varying lengths of wire remaining in the cabinet. It is the installers responsibility to properly trim and dress these wires in a fashion that not only leaves the wires organized, but also includes a service loop of suitable length.

<b>Procdure for speaker cable installation</b>	
1	Locate the siren wiring harness where it enters the electronic cabinet.
2	Locate the BLACK and RED wires marked 1 on their insulation. These wires are designated for connection to siren amplifier 1.
3	Route these wires through the cabinet's wire loom and connect to Amp 1
4	Repeat steps 2 and 3, substituting the appropriate number for all remaining amplifiers.
5	Ensure that speaker cable loop is trimmed, fixated and organized.



**ATTENTION: ONLY ONE CABLE SHOULD BE INSTALLED PR SCREW TERMINAL!**

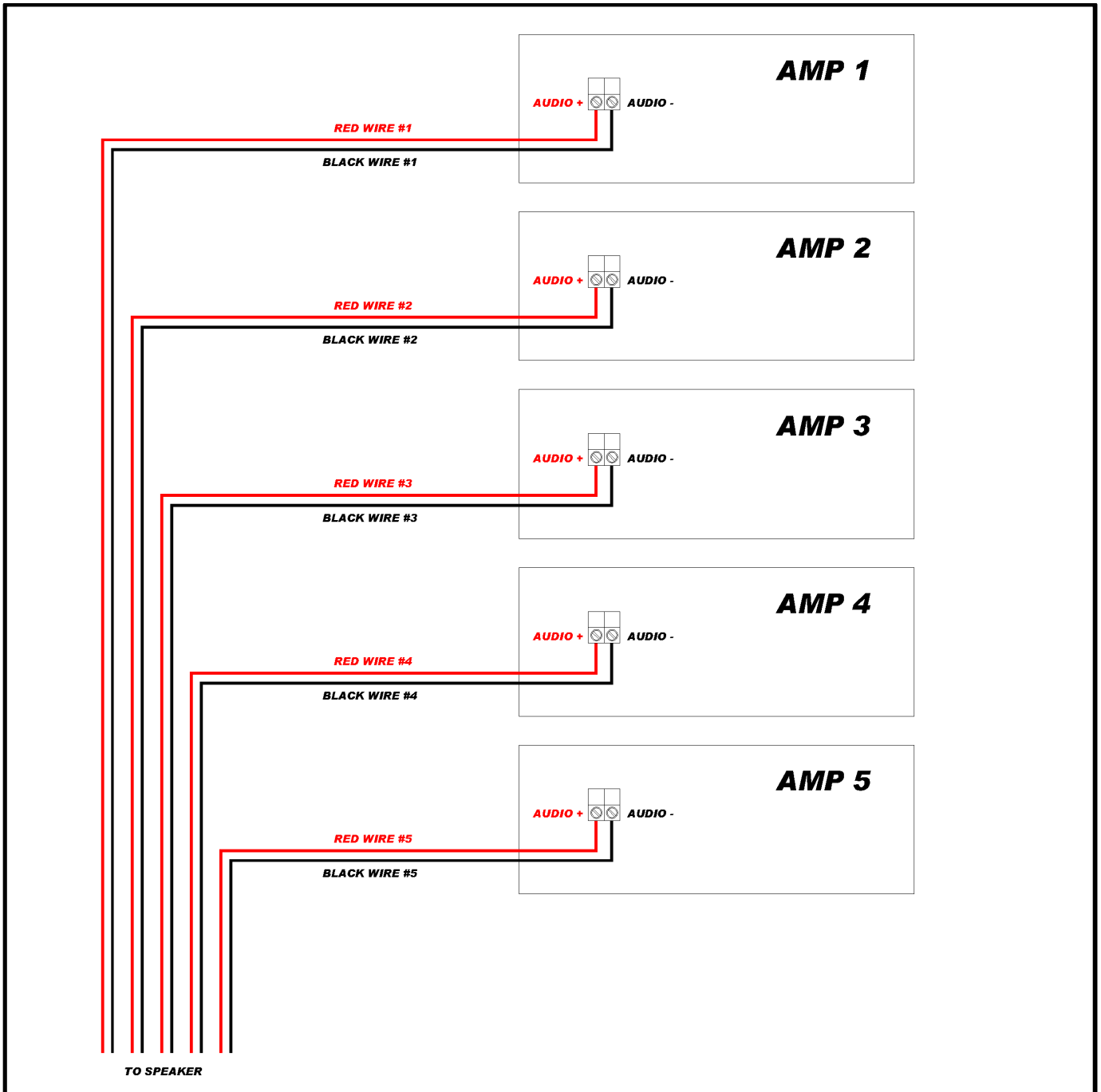



## 5. SERVICE AND TROUBLESHOOTING

### 5.1 SIREN CLUSTER

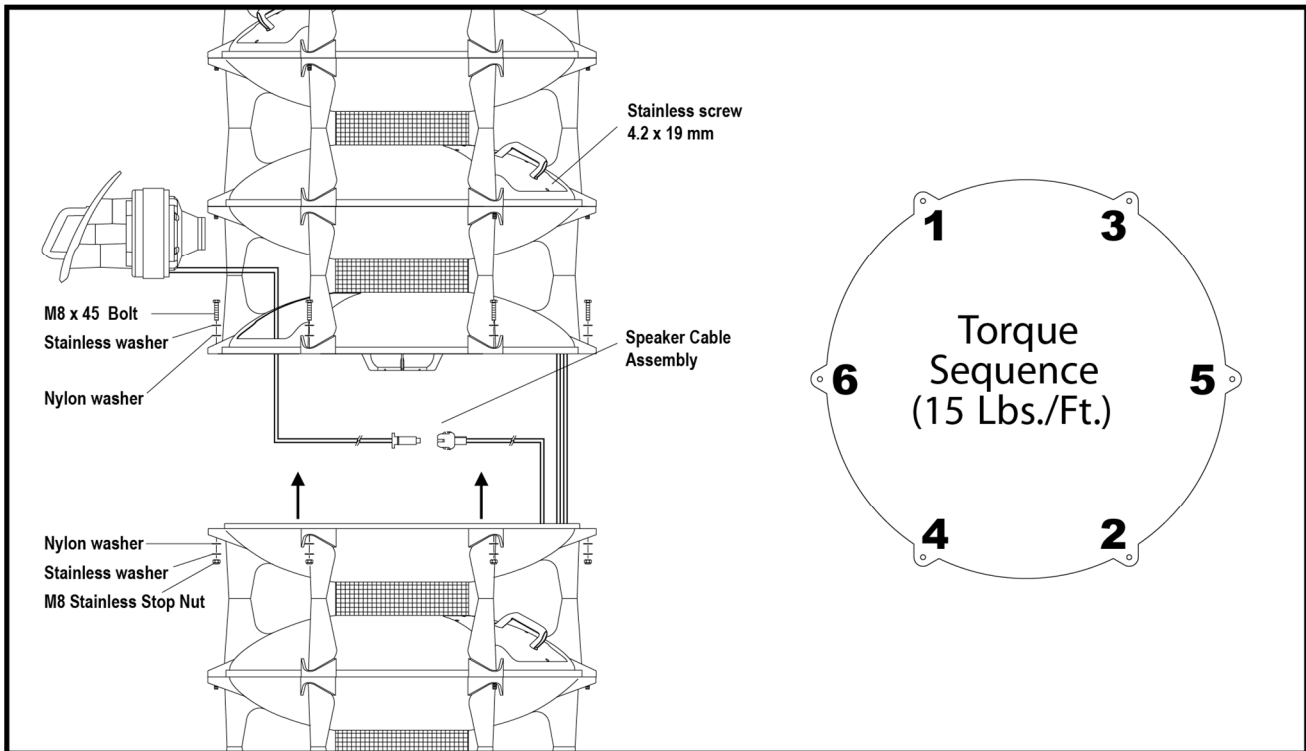

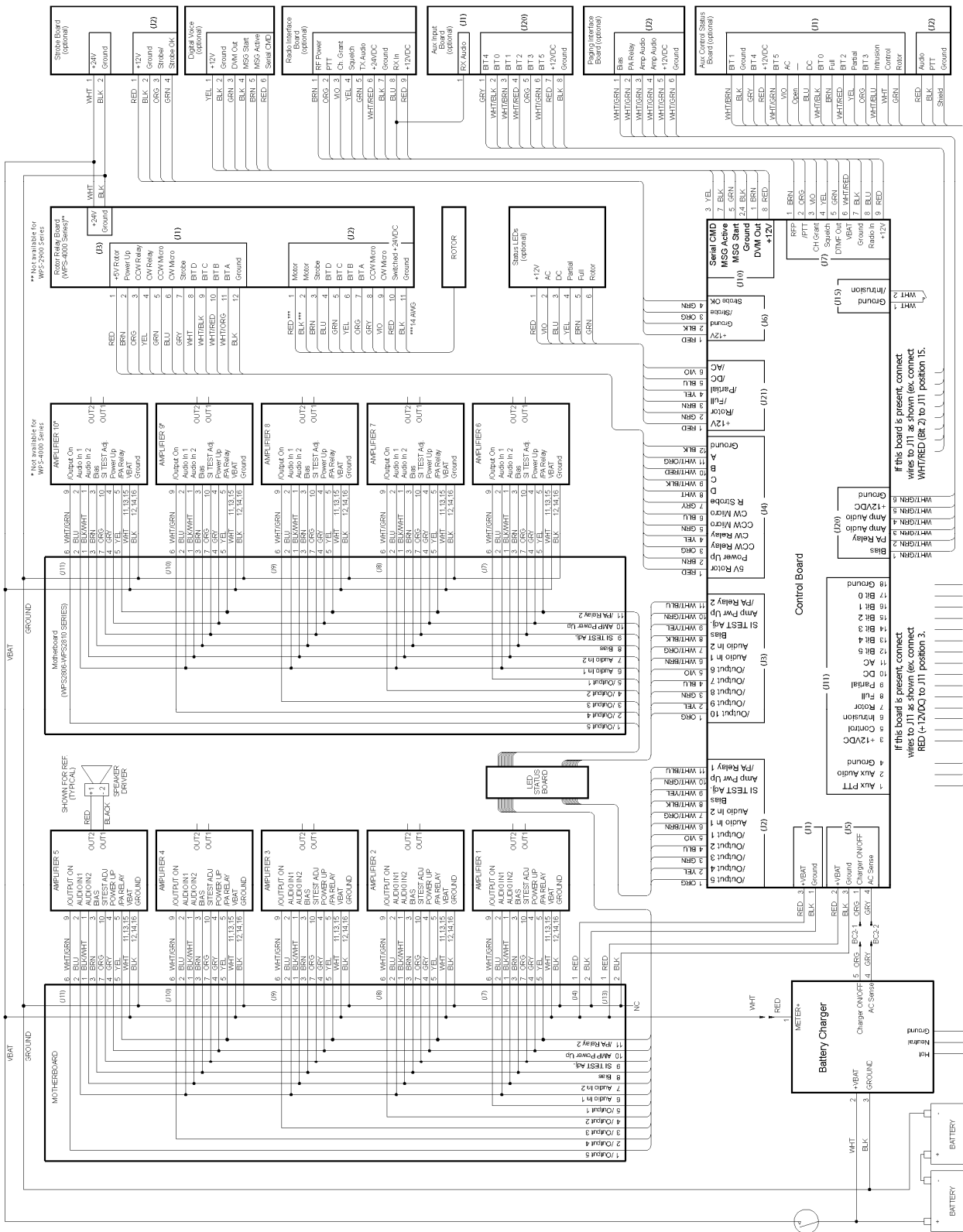
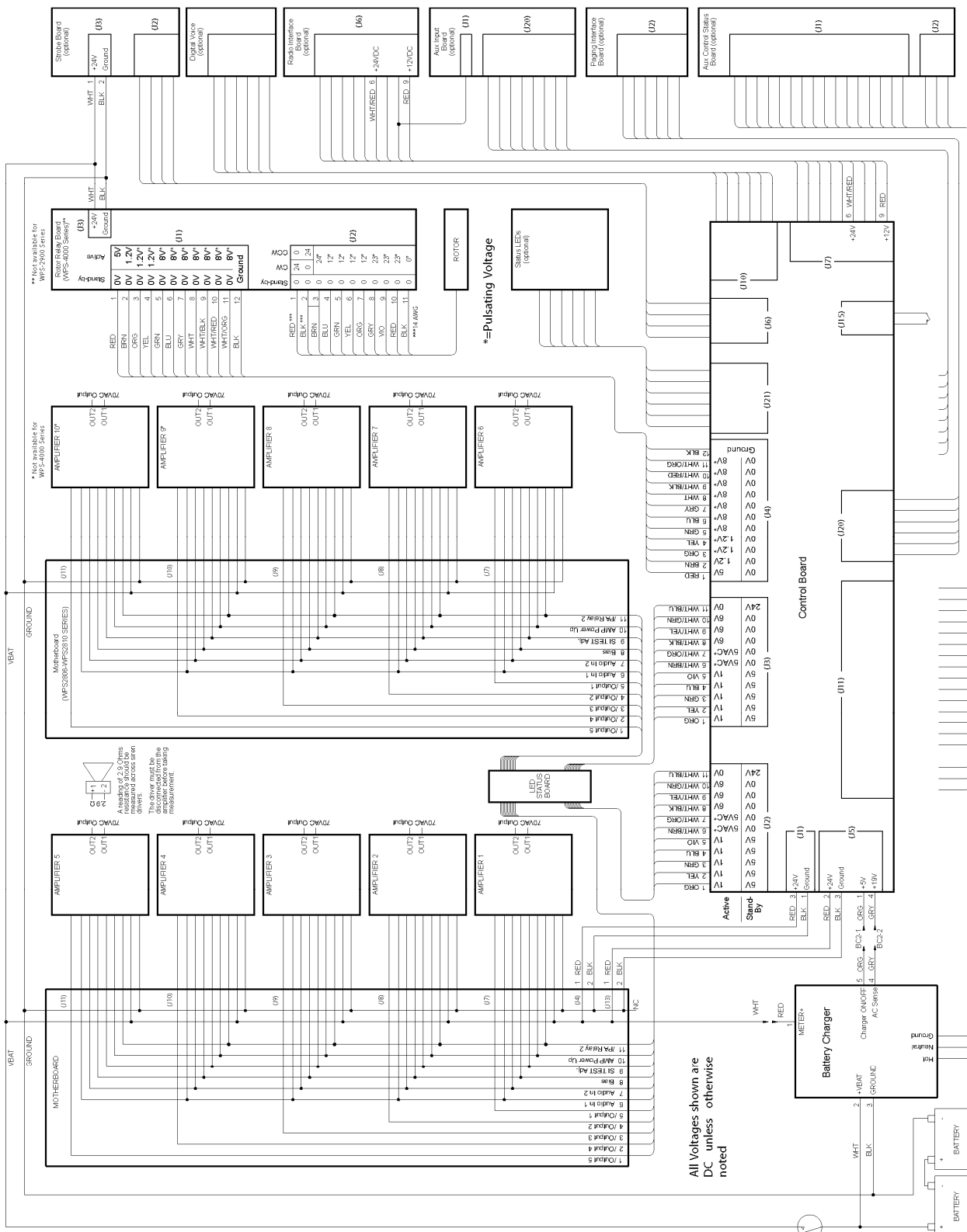

Figure 8 - Station Wiring Diagram (Designations)



**Figure 9 - Station Wiring Diagram (Voltages)**

## 5.2 STATION COMPONENTS DEFINED

---

*Control Board* - This component (located on the inside of the upper cabinet door) controls the key functions of the TWS SIREN SERIES system including:

- Tone Generation Remote Activation
- Event Timing Rotor Control
- Remote Station Status Reporting\* (encoding) Local Control
- System Diagnostics (incl. SI TEST®)

The control board contains a microphone jack for public address and a serial port to allow connection of our Siren Diagnostic Programming Tool Software (hereafter referred to as SDPTS) to the remote station. The control board is also the location of the diagnostic LED's.

*Siren Amps* - These components (located on the inside of the upper cabinet door) receive the desired tone or message generated by the control board, amplify it and deliver it to the siren driver.

*Siren Driver* - This component (located in the speaker assembly) produces the desired audible tone or voice message.

*Radio or Landline Board (Optional)* - This component (located on the inside of the upper cabinet door) receives signals from either the antenna or landline and delivers them to the control board for processing. Through the use of the included radio, the station is also capable of transmitting status information back to the control center.

*Motherboard* - This component (located on the inside of the upper cabinet door) distributes Battery Voltage and signals to all system components that require this voltage. The motherboard is fused @10 Amps to protect all connected components EXCEPT for the siren amplifiers and the rotor (they contain their own fuse). The Motherboard also distributes signals between the amplifiers and the control board.  
*AC Battery Charger* - This component (located on the of the lower part of mounting plate) uses 110/220 VAC single-phase service to maintain the stations batteries at their proper voltages.

*Solar Regulator (optional)* - This component (located on the lower left part of the mounting plate) uses electrical energy collected by a pole-mounted solar panel to maintain the station batteries at their proper voltages.

*Auxiliary Control Status Board (optional)* - This component (located on the right inside wall of the upper cabinet) is wired to remote switches to facilitate remote operation of a specific siren station.

*Auxiliary Input Control (optional)* - This component (located below the "Radio/Landline Board" on the rear inside wall of the upper cabinet) is wired to remote switches to facilitate limited remote operation of a siren station. In contrast to the Auxiliary Control Status Board, the Auxiliary Input Control Board does not offer feedback capabilities and is limited to the following remote activation commands:

- All Siren Tones
- Cancel
- SI TEST®

- Digital Voice Messages 1 thru 4

*Batteries* - These components (located on the inside of the lower cabinet) provide the 28VDC necessary for the system to operate.

*Battery Disconnect Switch* - This component (located on the rear inside wall of the upper cabinet) allows all system batteries to be completely disconnected from the system.

*Antenna Poly Phaser (optional)* - This component suppresses high-voltage (static) charges that could be present on the antenna.

*Antenna (optional)* - This component (located on the utility pole) is capable of either receiving signals broadcast from the control center (one-way) or can both transmit and receive signals to and from the control center (two-way), depending how the system was ordered.

*Solar Panel (optional)* - This component (located on the utility pole) collects solar energy, converts it to electrical energy and delivers it to the Solar Regulator to maintain the station batteries at their proper voltage.

*Strobe Control Board (optional)* - This component (located on the rear inside wall of the upper cabinet) is a user-defined device that controls a pole-mounted strobe light. This light can be configured to activate during specific conditions (example: when any tone or message is generated).

*Intrusion Alarm (optional)* - This sensor (located on the door jam of the upper cabinet door) detects the opening of the cabinet door. If the station is equipped with this option, the alarm is configured to transmit a signal back to the control center.

*Paging Interface (optional)* - This component (located below the "Strobe Control Board" on the rear inside wall of the upper cabinet) is a user-defined device that serves as an interface between the siren cabinet and an existing, in-house public address system. This board has an output relay with a 1 Amp rated closure that can be used for a "Push To Talk" function.

## 6. SYSTEM OPERATIONS

### 6.1 REMOTE OPERATIONS

---

Remote operation of a WPS-2900 series siren involves transmitting signals from the control center to the desired station. This is accomplished by using either an encoder and transmitter or, if the station is so equipped, using an auxiliary control status board that has been wired to switches/controls at the control center. Remote operation is beyond the scope of this document and will therefore not be addressed. If your system is equipped with an encoder, please refer to the encoder operating manual for information regarding remote operation. If your station has been wired to use the auxiliary control status board, refer to the reference materials provided by the electrical engineer or installer.

### 6.2 LOCAL OPERATIONS

---

Local operation is accomplished through the control panel on the front of the station cabinet. The functions of these controls are as follows:

CANCEL	Abruptly stops siren tones without the normal “ramp down” found in several tones. Helpful in the event of an accidental tone activation.
WAIL	Produces a slow rise and fall tone.
ATTACK	Produces a faster rise and fall tone (used for designated Civil Defense National Attack tone).
ALERT	A steady tone (Civil Defense alert).
WHOOP	A repetitive rise-only tone.
HI-LO	An alternating two-tone sound.
AIRHORN	A pulsing air horn sound.
SI-TEST®	Initiates SI TEST® tone and the optional diagnostic SI TEST® routine.
X-MIT CARRIER	Actuates remote station radio transmitter PTT circuit. When tone squelch is used with the transmitter, the transmit function is used when adjusting tone squelch modulation.
X-MIT AUDIO	For use with remote station radio transceiver, causes transmission of DTMF tone via RF link for tone modulation adjustment. The transmit tone level is adjusted with the transmit audio potentiometer located on the controller board (see “Fig. 11: System LED Diagnostic Indicators”)
X-MIT STATUS	Transmits station status information and battery

	voltage to the control center.
DVM TEST	Activates the Digital Voice Message (DVM) assigned to the test procedure in the configuration software.
ROTOR CW	No function with TWS siren
ROTOR CCW	No function with TWS siren
KEYPAD ARM	<p>Enables local station operation via keypad. Once pressed, the keypad remains active until either</p> <ul style="list-style-type: none"> <li>a) another keypad button is pressed, or</li> <li>b) 60 seconds have elapsed, whichever comes first.</li> </ul> <p>The Keypad Arm button must be pressed each time a keypad button is to be pressed. Note that the Cancel button is always enabled and does not require Keypad Arm to be pressed.</p>

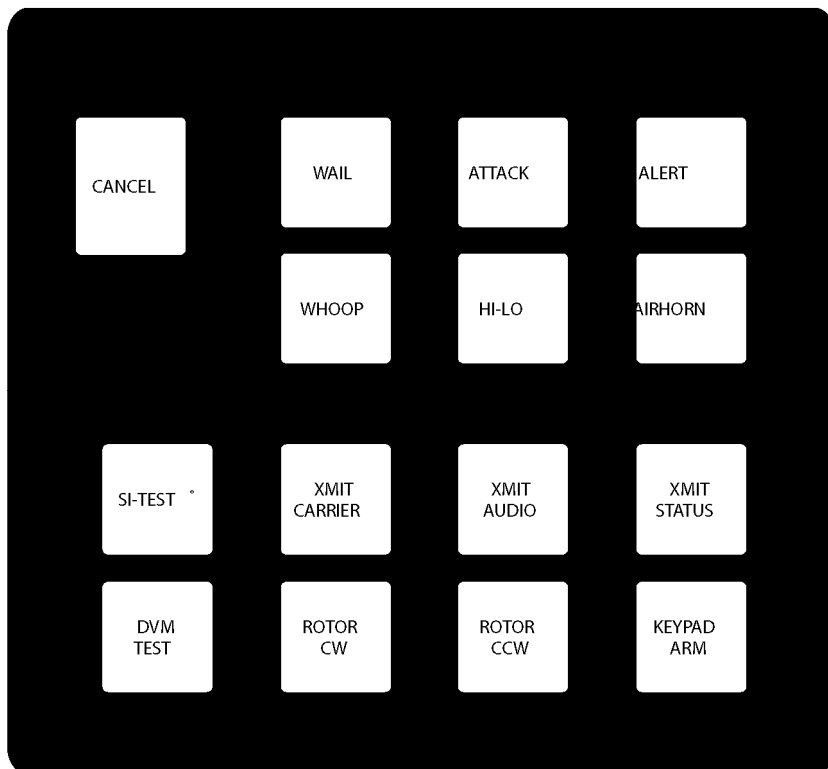

**Figure 10 - Station Control Panel**

## 7. UNDERSTANDING STATION ADDRESSING

Every Siren Station in a given area code has its own, unique “Station Address”. This address allows the user to select an individual or a group of stations. As stated elsewhere in this manual, a valid station address can be any number from 0000 to 9999. This allows for 10,000 unique addresses; a staggering number of stations to keep track of. Although it is logistically impossible to have that many stations in a single area code, it does illustrate the importance of a sensible, intuitive numbering convention for station addresses. This section will outline two types of conventions *Central Point Source: Quadrant, Sector, Radial & Station* Frequently, warning systems are used to notify the public of emergency situations that may occur from a single, centralized location. Typically, siren stations would be located throughout a 360° area surrounding this location for a specified distance from the source. In this scenario, the Central Point Source convention would be well suited. For illustration purposes, assume the siren stations are installed within a 5 mile radius of the Central Point. As such, a Quadrant, Sector, Radial & Station numbering convention would allow the selection of any of the following:

- any siren station
- all siren stations
- any one of four sectors
- any one of 5 radii within the sectors

The area of coverage in this system, a circle, is divided into 4 quadrants. Each quadrant is then divided into 4 sectors. Each sector is further divided into 5 segments or radii emanating from the center of this siren system.

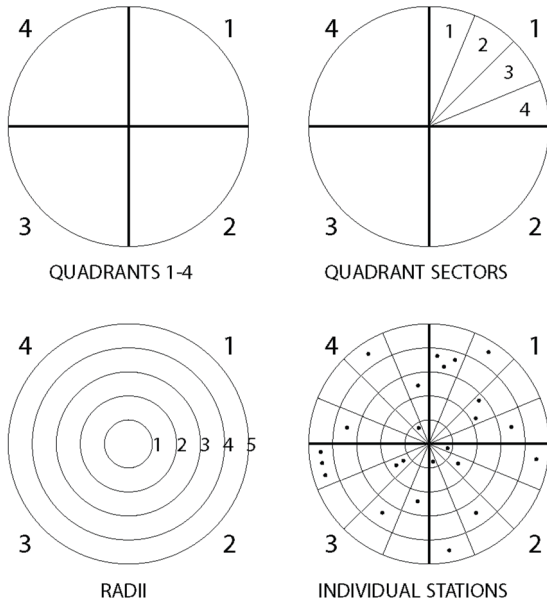

**Figure 11 - Central Point Source Divisions**



In this system, a stations address is structured as follows:

Digit	Allocation
1	Quadrant (1 to 4)
2	Sector (1 to 4)
3	Radii (1 to 5)
4	Individual station within a radian

Here are some sample activations to further illustrate this concept.

**Sample 1:**

A station with address 1354 would be located in:

Quadrant: 1

Sector: 3 of Quadrant 1

Radial: 5

Station: 4

If an operator selects station 1-3-5-4, only that station will be selected, as shown.

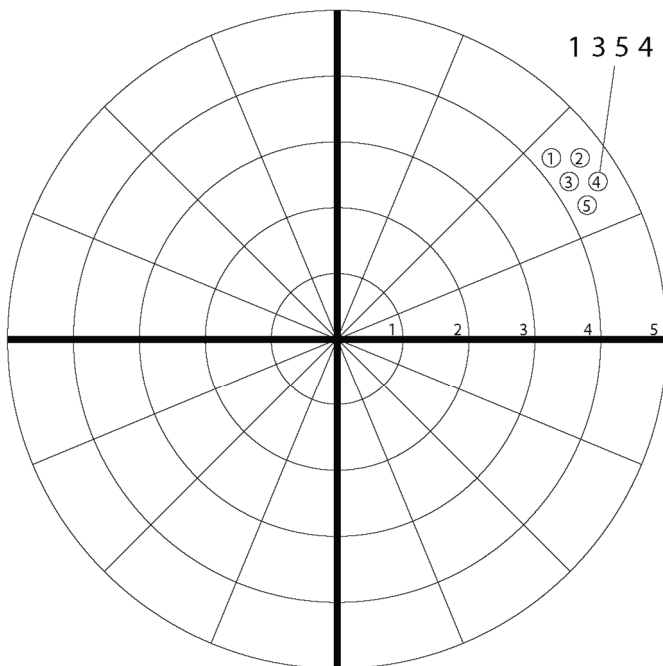

**SINGLE STATION SELECTION  
 STATION 1354**

**Figure 12 - Single Station Selection**

**Sample 2:**

If the activation of a group of remote stations within a whole segment of a radius within a quadrant and sector is desired, the fourth digit address is substituted with a "Wild Card", the "#" pound sign. An address selection of 1 - 3 - 4 - # would activate the system as follows:

Quadrant: 1

Sector: 3 of Quadrant 1

Radial: 4

Station: # All stations defined by above

This selection is shown below.

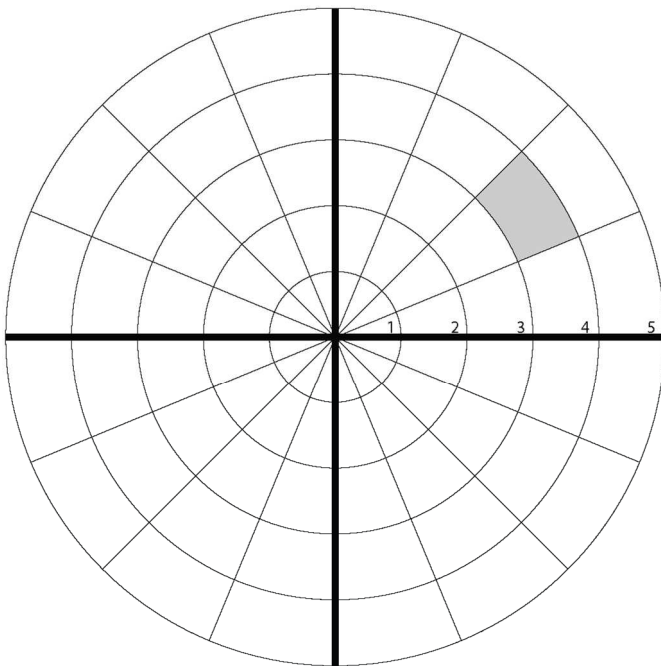

GROUP SELECTION-RADIAL SECTOR  
GROUP 134#

**Figure 13 - Group Selection - Radial Sector**

**Sample 3:**

Selection of an entire sector can be accomplished by using the following address:

Quadrant: 1

Sector: 3 of Quadrant 1

Radial: # All radial 1 - 3

Station: # All stations defined by above

In selecting a sector, the first two digits of the address are set for the sector address, for example 1 - 3 (Quadrant 1 - Sector 3). The third and fourth digits are substituted with a # (Wild Card). Therefore, the address to select all stations in sector 1-3 is 1 - 3 - # - #. This selection is represented below.

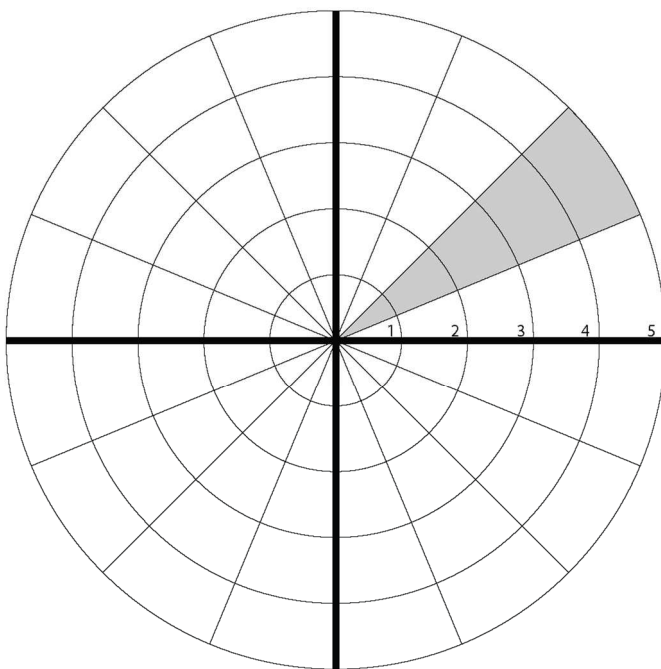

GROUP SELECTION-SUB-SECTOR  
 GROUP13##

**Figure 14 - Group Selection - Sub Sector**

**Sample 4:**

The selection of a complete quadrant can be achieved by using the following address:

Quadrant: 1

Sector: # All sectors of Quadrant 1

Radial: # All radials in all sectors of Quadrant 1

Station: # All stations defined by above

When selecting a quadrant, the first digit designates the Quadrant (1). the second, third and fourth digits are replaced with Wild Cards (#,#,#). Therefore, the address for selecting all stations in quadrant 1 is 1 - # - # - # as illustrated below.

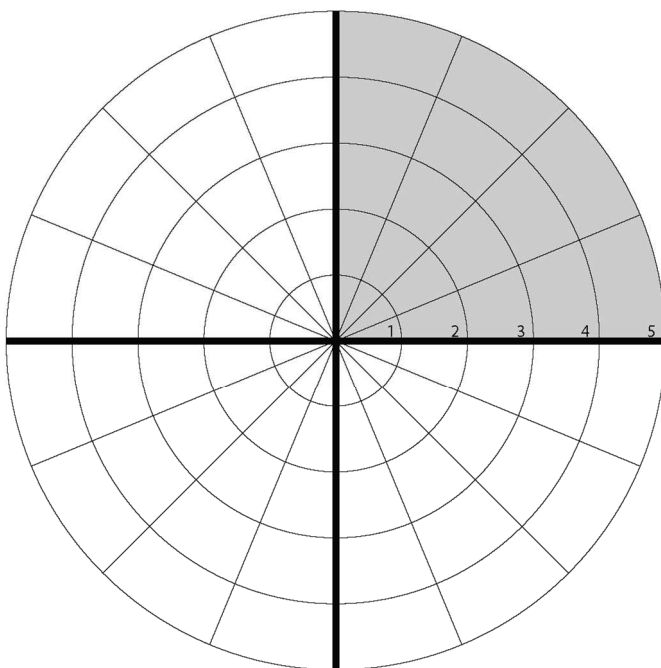

GROUP SELECTION-QUADRANT  
 GROUP###

**Figure 15 - Group Selection - Quadrant**

**Sample 5:**

All stations in a system may be accessed by using the Wild Card (#) for all address numbers.

The address would be # - # - # - #.

Quadrant: # All Quadrants

Sector: # All sectors of all Quadrant

Radial: # All radials of all sectors of all Quadrants

Station: # All stations defined by above

This "All Call" is illustrated as shown.

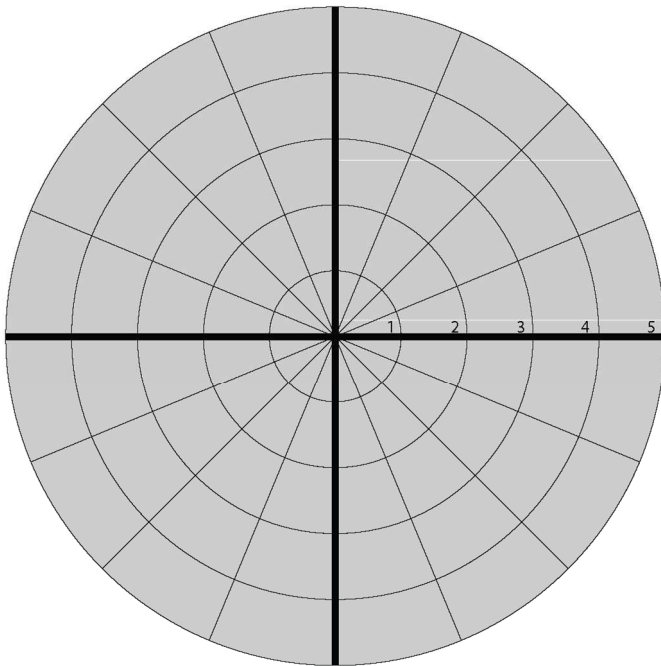

GROUP SELECTION-"ALL-CALL"  
GROUP #####

**Figure 16 - Group Selection - All Call**

**Governmental: County, City & Station**

For this next type of address structure, assume that the siren system in question is used primarily for tornado warnings throughout a major population center. This center encompasses three counties with each county having no more than ten cities. Two cities contain more than 50 high-power voice and siren stations.

The following represents a Governmental System 4-digit address configuration, allowing activation by “All Call”, county group activations, city group activations and individual station activations:

X X X X

:::.....:..... Individual Siren Station (00 - 99)

::

:::..... City (0 - 9)\*

:

:::..... County (0 - 9)

\*One digit could also be reserved for unincorporated areas.

An address of 2 - 5 - 4 - 5 would indicate the following individual station:

Siren Station 45, in City 5, in County 2.

The Wild Card (#) permits the use of several different types of group activations. Three samples follow:

Sample 1: County Activation (1 - # - # - #)

All Siren Stations in all Cities in County 1 will be activated by this transmission.

Sample 2: City Activation (1 - 5 - # - #)

All Siren Stations in City 5 of County 1 will be activated by this transmission.

Sample 3: System All Call (# - # - # - #)

All Siren Stations in all Cities in all Counties will be activated by this transmission.

## 7.1 TROUBLESHOOTING

---

### 7.1.1 AUDIO LOSS

If after activating the siren there is no audio output, perform the following procedure step by step. This procedure will require a digital multimeter.

1. Locate the Audio Presence LED on the controller board (see “Fig. 11: System LED Diagnostic Indicators” on page 29). When audio is present on the board, this LED will be on.
2. Activate the WAIL siren tone from the control panel on the siren cabinet. Confirm that the Audio Presence LED is on. If this LED is not on *or* if it turns off quickly, measure the battery voltage. The siren will not activate if battery voltage drops below 19 VDC. Be sure to measure the battery voltage at the same time you activate the siren. The batteries may show a good float voltage while they are not under load, but upon activation, the battery voltage may drop below 19 VDC if their capacity is low. Note that when the siren shuts down and the load is removed from the batteries, the voltage may rapidly return to 25 VDC or more. If this condition is occurring, the batteries will need to be replaced. If the voltages are in the normal range, proceed to step 3.

3. Locate connector J2 on the control board. With your multimeter set to AC volts, measure across pins 6 and 7 (White with Orange stripe and White with Brown stripe). With the siren tone running, 5 VAC should be present. *If no voltage is present, the controller board is probably at fault.*

NOTE: Confirm that the audio presence LED is on while performing these measurements. It indicates that the siren controller is still activated. If the specified voltages are present, proceed to step 4.

4. With the siren tone still active, measure across pin 1 (Blue wire) and pin 2 (Black w/White trace) on each of the siren amplifiers. 5 VAC should be present at each amplifier. If so, proceed to step 5. If no voltage is measured, this is indicative of a wiring problem between the controller board and the siren amplifiers. Check the wiring between these components
5. Remove the Red siren driver lead from each siren amplifier. Press “Cancel” on the control panel and then press “Wail”. Measure across the output of each amplifier (White Weco connector) with the siren driver disconnected. 70 VAC should be measured. If this voltage level is measured, proceed to step 6. If this voltage level is not found and 5 VAC was measured at the input, proceed to step 7.
6. Set your meter to measure resistance at its lowest scale. Measure across each of the speaker drivers, making sure that at least one wire of each driver is removed from the power amplifier (or else the transformer in the amp is being measured as well). Each driver should have a DC resistance of approximately 3 Ohms +/- .3 Ohms. If a resistance value outside of this range is found, contact factory.
7. Set your meter to measure DC Volts. Connect the negative lead of your meter to ground (one of the solid black wires in the multi-position connector on the amplifier is a good ground source). With a siren tone activated, measure the following wires for the following voltages (approximately):  
Grey 6 VDC  
Brown 5 VDC  
Solid White (all) 24 VDC

**7.1.2 AC BATTERY CHARGER**

The AC-powered battery charger has two charging modes: Equalization Mode and Float Charge Mode. The charger is in equalization mode when AC power is first applied; the charger will stay in equalization mode until the battery voltage reaches approximately 30VDC. Once the battery voltage reaches that point, the charger will switch to float voltage mode. In that mode it will charge the batteries to the appropriate voltage relative to the temperature of the batteries (25 to 29VDC).

**7.1.3 SOLAR REGULATOR**

The following procedure can be performed to confirm proper operation of the solar regulator:

1. Disconnect the solar panel from the charger. With a DC voltmeter, measure the voltage across the wires coming from the solar panel. The voltage should be greater than 32 VDC (NOTE: The solar panel must be in direct sunlight).
2. Reconnect the solar panel to the charger. Monitor the battery voltage with the cabinet voltmeter. The float voltage will vary between 25 to 30 VDC, depending on battery temperature. When the solar regulator is charging, the DC LED on the circuit board will be on. During normal operation the charger will cycle on and off.

Pin Position 1	RED - Battery Voltage to Ground (BLK wire in BC-1) Note: Voltage present only when siren is powered up.; this is sourced from the siren motherboard
Pin Position 2	WHITE - Charger output wires (25 to 31 VDC)
Pin Position 3	BLACK – Charger output wires (25 to 31 VDC)
Pin Position 4	GREY - 19VDC from GREY to Ground (BLK wire in BC-1)
Pin Position 5	ORANGE - VDC from ORANGE to Ground (BLK wire in BC-1)
Pin Position 6	Not Used

The float voltage will vary with battery temperature. The following is a brief description of the normal charging cycle:

If the float voltage for the current temperature of the batteries is 26 VDC, the regulator will turn on at 26 VDC (LED will come on) and it will charge the batteries to 28 VDC. Once the battery voltage reaches 28 VDC, the regulator will turn off (LED will go off), and the battery voltage will be allowed to drop to 26 VDC. The cycle would then repeat itself. If the float voltage was 27 VDC, it would cycle from 27 VDC to 29 VDC. When AC power is applied to the battery charger, the following voltages should be measured on the wires coming off the charger:

Note: Refer to “Station Wiring Diagram (designations)”



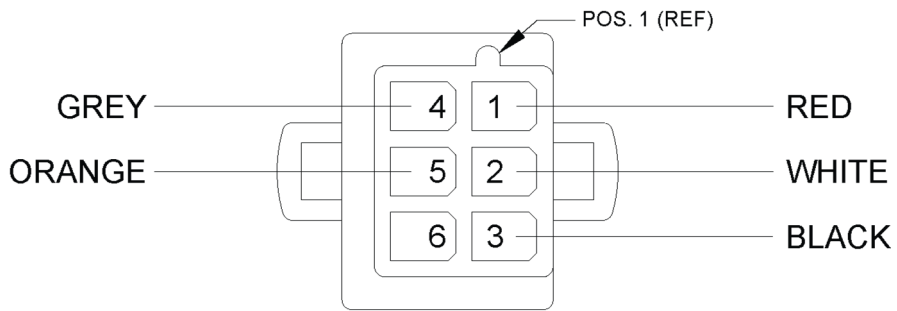

REAR VIEW OF PIN HOUSING

**Figure 17 - Solar Regulator Connector Pin-Outs**

#### 7.1.4 DIGITAL VOICE

1. Remove all amplifier fuses.
2. Install an 8 ohm speaker at amplifier audio input connector pins 1 and 2 (Blue and Black w/White wires) in the 16 position connector.
3. Select a siren tone by pressing one of the controls on the front panel.
4. If the tone can be heard through the speaker, press the DVM-Test control to play the predesignated message.

#### 7.1.5 PARTIAL OR FULL DIAGNOSTIC FAILURE

This procedure is to be used if the Partial or Full diagnostic LED (located on the controller board) indicates that a problem has been detected. A Partial indication means that at least one speaker and/or amplifier is operational. A Full indication means that all speakers and amplifiers are operational. *NOTE: In order for a good Full indicator to be valid, a good Partial indicator must also be present.*

1. Connect the SDPTS to the siren station *via* the com port on the front of the siren cabinet control panel.
2. Display the "Status" screen on the SDPTS.
3. Press the SI TEST® control on the front control panel.
4. Each amplifier contains a red LED that is visible on the front of the control panel. Note if all the LED's are on. Tap the "Update Status" button on the SDPTS and note which amp is displaying an error.
5. Open the front panel and swap the speaker driver wires from the amplifier that indicated a failure, with an amplifier with a lit LED. For example: if the LED for amplifier 1 is the only LED not on, install amplifier 1 speaker wires onto amplifier 2 and install amplifier 2 speaker wires onto amplifier 1. This will diagnose if it is the speaker or the amplifier that has failed. You may also measure the DC resistance of the speaker driver with your ohm meter. Be sure that the speaker driver wires are disconnected from the amp prior to measuring. A good driver will read 3 ohms +/- .3 ohms.

## 8. MAINTENANCE

---

Although the TWS SERIES SIREN is of a dependable, solid-state design, periodic activation, field inspection and preventive maintenance is recommended to insure the maximum performance of each station.

### 8.1 FREQUENCY OF TESTING AND ACTIVATION

---

A system of twice-monthly activation and confirmation, combined with a quarterly service and preventive maintenance is recommended to help insure the successful performance of a station. Increasing the frequency of testing will support and improve a station's test record.

Stations located in environmentally adverse locations will require inspection and preventive maintenance at more frequent intervals than just discussed.

**IMPORTANT! STATIONS SHOULD ALWAYS BE INSPECTED IMMEDIATELY FOLLOWING SEVERE STORMS.**

If a station is activated by remote control (landline or radio), the twice-monthly activation should be performed using the remote control link.

The twice-monthly activation of a station can be confirmed by several different methods, depending upon the options selected with each Whelen System.

#### *Local Site Confirmation*

For a basic station activated at the cabinet, or by landline or radio, have an observer confirm that the station activated audibly. The observer should report successful as well as failed station tests. Station Performance Logs should be maintained. It is important to understand that audible confirmation alone is not assurance that the station is operating at 100% power. This requires inspecting the station in greater detail.

Stations may be optionally equipped with counters that advance upon radio or tone generator activation. These counters do not confirm total operation or the final expected output of an outdoor warning device. If a station is equipped with the "Status Display" option, full power station activation can be visually confirmed from outside the siren cabinet. This diagnostic display, located on the right side of the cabinet, will indicate the following:

(from left to right)

Red	indicates the presence of AC power (if equipped with an AC Battery Charger)
Yellow	indicates the presence of DC power at minimum operating level (at least 19VDC)
Red	indicates partial amplifier/driver function
Green	indicates full amplifier/driver function
Red	indicates rotor operation (WPS-4000 systems only)

This diagnostic function is enabled by either a full power siren tone activation or by performing a SI TEST®.

The same information is available on the control board LED numbers 4 - 8. The "Status" option is not required for the on-board LED's to function.

Following activation and observation, the results should be noted in the performance log. Any indication of incomplete operation presented by the LED indicators should prompt IMMEDIATE service attention.

The system retains diagnostic information until cleared by a specific command.

The diagnostic information stored at the station, if not cleared, will update itself automatically with subsequent SI TEST® or siren tone activations.

### *Remote Monitoring and Confirmation*

Stations equipped with the optional Whelen COMM/STAT™ Command and Status Monitoring control, allow remote monitoring of status as well as confirmation of system activation. COMM/STAT™ returns the results of a remote station activation (both SI TEST® and siren warning mode) in a DTMF encoded format via radio link.

Remote monitoring by RF link eliminates the necessity of physically visiting a station to confirm an activation.

Following the activation of a station, a "Status Request" may be sent to that station by DTMF encoded radio command. Diagnostic information is then presented to the status encoder at the station, converted into DTMF code and transmitted back to the control center, where one of several COMM/STAT™ base station products will convert the DTMF code into meaningful information.

## **8.2 QUARTERLY MAINTENANCE**

---

Developing a quarterly inspection and preventive maintenance program for an outdoor warning station requires a thorough understanding of all the elements and expectations of the system. The following section provides an overview and basic guideline for quarterly station inspection and preventive maintenance program for the sample station.

### **8.3 VISUAL SIREN STATION PHYSICAL INSPECTION**

---

- Observe the speaker cluster, siren cabinet and AC Service for any signs of damage or loose mounting hardware (Some shrinkage of a newly treated utility pole may occur in the first several years following installation, requiring the tightening of mounting hardware).
- Check all conduit for watertight connection and entrance into the siren cabinet.
- Inspect the AC Service for damage, blown fuses, degraded (corroded) power connections and integrity of the lightning arrestor.
- Inspect the grounding system for AC Service, Siren Cabinet and pole top equipment. Verify connections and acceptability of earth ground.
- Observe the pole for any shifting and/or leaning. Poles that are not plumb will not properly direct alerting sounds.
- Examine entire station for any signs of vandalism or forced entry.

### 8.3.1 Siren Cabinet and Components

- Inspect AC Outlet, fuse and surge suppression equipment. Examine system for infiltration of foreign material(s), rodents, insects or other pests.
- Inspect and, if necessary, clean all drain holes and vent screens.
- Inspect battery terminal connections and clean if necessary. Re-apply silicone coating to battery terminals if necessary. Observe battery voltage with siren in inactive state (AC power must be on to station, otherwise station must be powered up to observe meter).
- Examine all wiring harnesses for chafing. Verify wiring terminations for tightness and wiring connections for proper electrical connections. Replace and correct any corroded or marginal connections. Inspect antenna for proper connection.

### 8.3.2 Speaker Assembly and Pole Top Equipment

NOTE: Any examination of Pole Top equipment should be performed with the station audibly disabled.

- Inspect speaker for blockage by rodents, pests, insects or other foreign material. Clean if necessary. Inspect any wiring cables or harnesses for chafing. Inspect the siren driver compartment for infiltration of foreign materials, rodents or pests. Clean if necessary.

Confirm that the driver compartment will allow for water or moisture drainage. Inspect speaker wiring connections for any sign of corrosion.

- Verify tightness of all mounting hardware.
- Check all wiring terminations and connections.

### 8.3.3 Station Performance Testing

NOTE: Depending on local conditions and station options selected, the station may be tested on or off line. Off line testing of the station involves disconnecting the speaker drivers from the siren amplifiers, so as not to disturb the public when verifying tone generator operation. A complete test must, however, include the testing of the siren amplifier operation. This can be accomplished inaudibly using the SI TEST® command.

A basic routine, verifying the performance and operation of the sample station previously described, would be as follows:

1. Local and Remote Activation - Activation of each remote station function by local control and remote control. With amplifiers on and off line as needed. An examination of each activation function will also facilitate a verification of related and subsequent system module activations and electrical connections that would be caused by an activation command. Also confirm function time outs (ex.: does the Alert signal time out at three minutes as per user specification?).
2. Response to Station Address and All Call address programming - Control Center reception and activation on SI TEST® or non-tone activation, for individual station address and All Call address selection.
3. Public Address - With the station on line, activation of PA for both local and remote control, verifying PA Audio path and proper set up level of volume.
4. Siren Amplifiers - Inspect for complete operation with speaker drivers (observe LED's).
5. SI TEST® Station Analysis - Observe and confirm diagnostic status of:
  - a. AC
  - b. DC
  - c. Partial Amplifier & Speaker Driver Operation (disable one amplifier to confirm this test).

- d. Full Amplifier & Speaker Driver Operation
- e. **NOTE:** Verify AC drop out during SI TEST® mode.
- 6. Battery Charger Operation
  - a. Observe for proper charging operation.
  - b. Verify AC drop out in PA or SI TEST® mode.
- 7. Batteries –
  - a. Verify voltage stability under load.
  - b. Perform a load test.
- 8. Status Encoder –
  - a. Perform a diagnostic SI TEST® of the station.
  - b. Compare status information with observations made locally at the station.
  - c. Disable one speaker and verify that the “Full” LED indicator is off.
  - d. Disable AC and verify that the “AC” LED indicator is off.
  - e. Compare battery voltage return status with observed and measured battery voltage.
- 9. Transmitter –
  - a. Check status encoder DTMF tone level modulation with transmitter.
  - b. Check transmitter set up.
  - c. Verify power output and SWR.

Wide Band		Narrow Band	
With CTCSS	3.1 kHz deviation	With CTCSS	1.8 kHz deviation
Without CTCSS	2.5 kHz deviation	Without CTCSS	1.5 kHz deviation

**NOTE:**On concluding any examination of a station where connectors have been opened and closed , a final radio test by either SI TEST® or full power should be performed and the results observed for a complete successful test. The PA audio path should also be audibly verified by sending PA and broadcast a voice message.

The following is a sample form that may be used for quarterly inspection and maintenance

<b>MAINTENANCE CHECK LIST</b>			
STATION#:		SIREN ADDRESS:	
INSTALLATION DATE:		INSPECTION DATE:	
INSPECTOR:			
<b>PHYSICAL INSPECTION</b>			
	OK	NOT OK	COMMENT
MOUNTING HARDWARE			
SPEAKER ASSEMBLY			
AC SERVICE			
GROUNDING			
SOLAR PANELS (OPTIONAL)			
ANETENNA			
CONDUIT CONNECTIONS			
SIREN CASE ASSEMBLY			
BATTERIES			
COMPONENTS SECURE			
HARNESS			
<b>LOCAL OPERATIONAL TESTING</b>			
BATTERY VOLTAGE (STAND-BY)			
BATTERY VOLTAGE (UNDER-LOAD)			
MANUAL TEST:			
CLEAR			
WAIL			
ATTACK			
ALERT			
AIRHORN			
HI/LO			
WHOOP			
CLOCKWISE			
COUNTER-CLOCKWISE			
SI-TEST®			
AC LED			
DC LED			
PARTIAL LED			
FULL LED			
ROTOR LED			
TIMER SET LED			
AUDIO PRESENT LED			
MICROPHONE			
MIC VOLUME			
SQUELSH CONTROL			
SENSITIVITY			
ANTENNA TUNES (OPTIONAL)			
TRANSMIT LED			
REMOTE ACTIVATION:			
CLEAR			
WAIL			
ATTACK			
ALERT			
PUBLIC ADDRESS			
AIRHORN			

HI/LO			
WHOOOP			
WAIL / 5 SEC			
ALL CALL			
SPEAKER LED'S			
1			
2			
3			
4			
5			
STATUS:			
AC			
DC			
PARTIAL			
FULL			
STATUS REQUEST			
INTRUSION (OPTIONAL)			



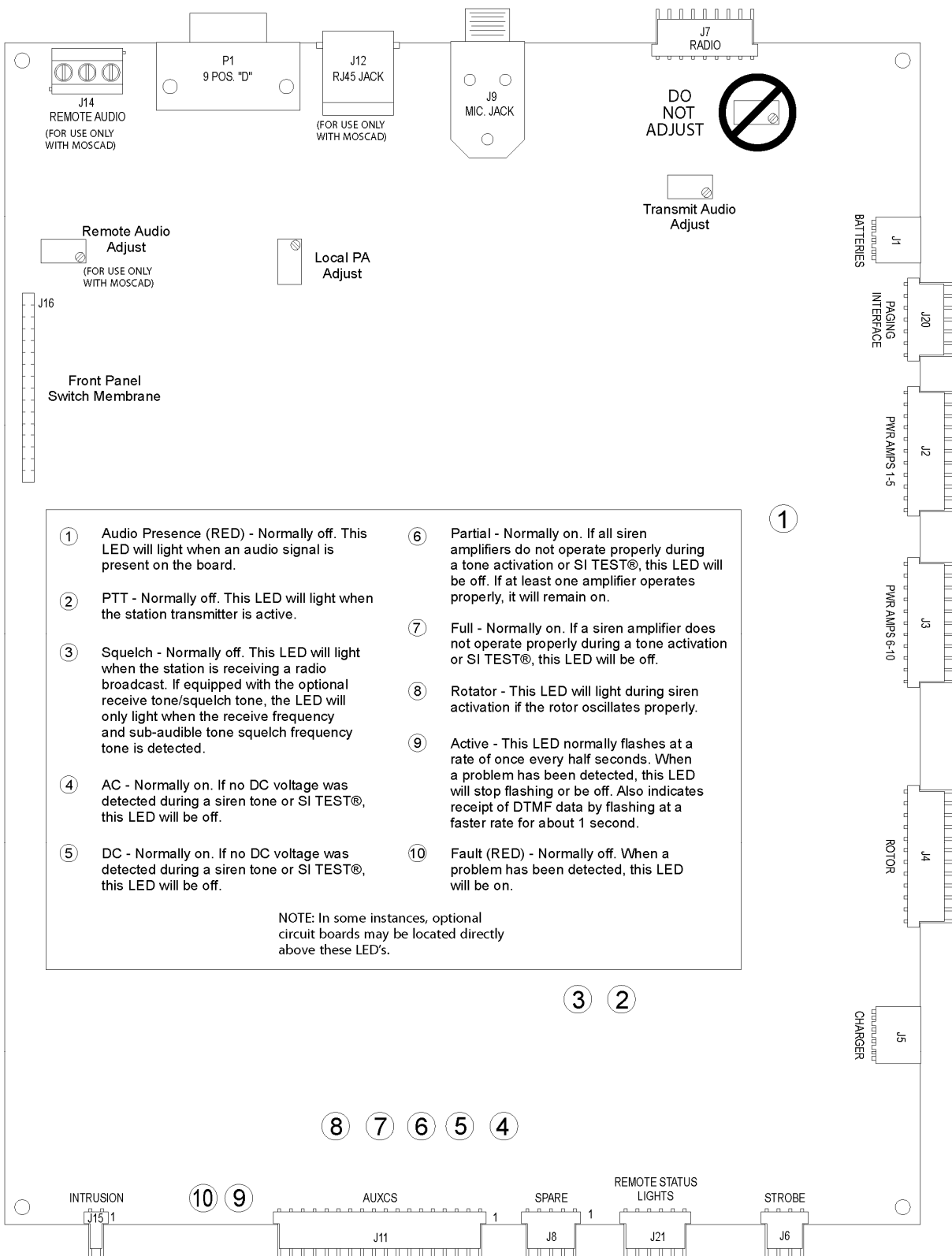

**Figure 18 - System LED Diagnostic Indicators**

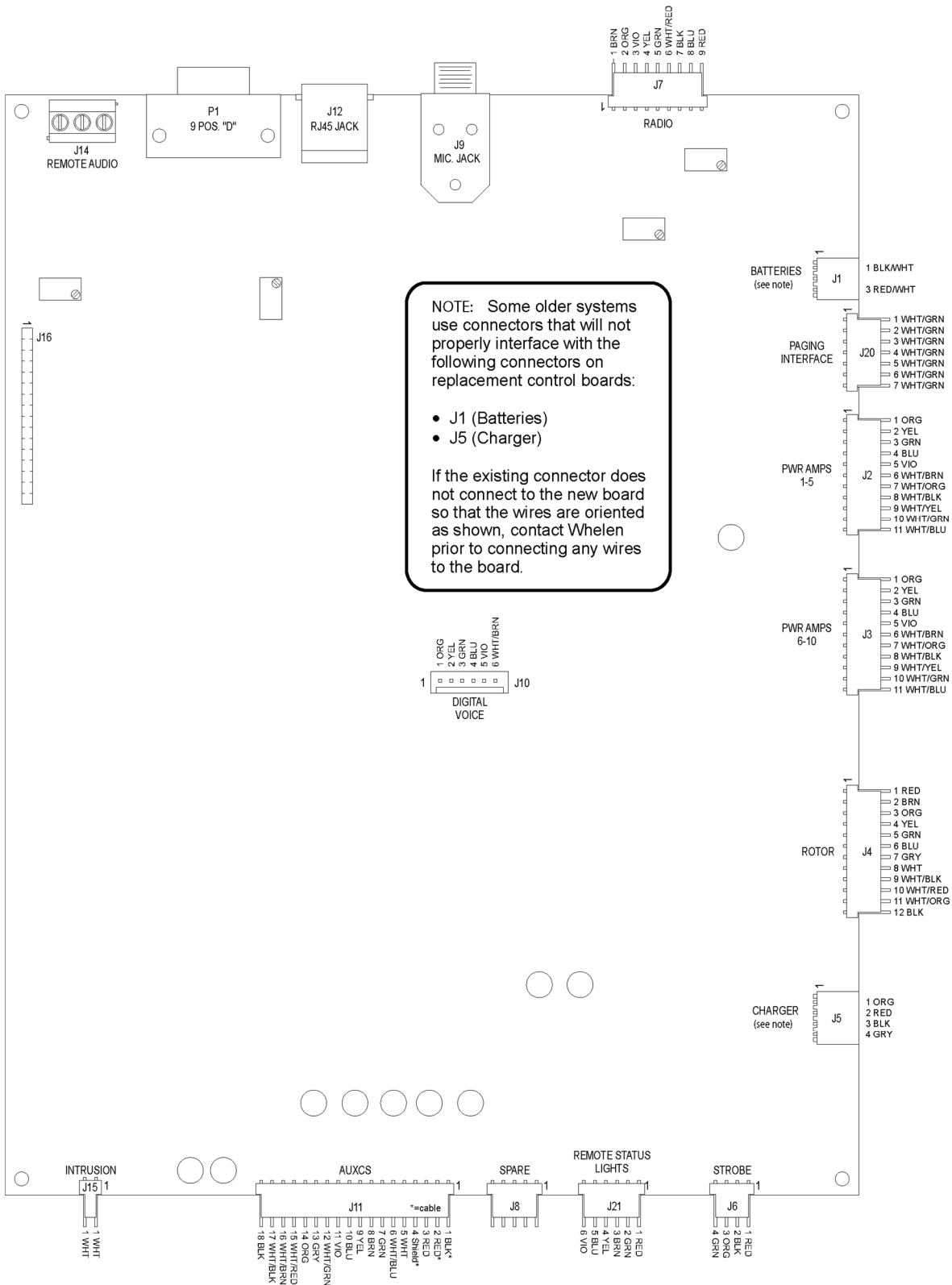

**Figure 19 - Control Board Wire Colors**